

# INSTALLATION, OPERATION AND MAINTENANCE MANUAL

## FIGURE 930

1/2" (15mm) through 4" (100mm)

**AIR & VACUUM VALVES  
FOR CLEAN FLUIDS**

***GA Industries, Inc.***

**9025 Marshall Road**

**Cranberry Township, PA 16066 USA**

**Telephone (724) 776-1020**

**Fax (724) 776-1254**

**E-mail: [info@gaindustries.com](mailto:info@gaindustries.com)**

# INSTALLATION, OPERATION and MAINTENANCE

## Figure 930 Air & Vacuum Valve

### INTRODUCTION

This manual will provide the information to properly install, operate and maintain the valve to ensure a long service life. The Figure 930 is ruggedly constructed to provide years of trouble-free operation with minimal maintenance.

The Figure 930 is not intended for use with fluids containing suspended solids such as wastewater and sewage. The GA Industries Figure 935 Air & Vacuum valve is recommended for such applications.

**CAUTION:** The valve is NOT recommended for use with toxic fluids, fuels or fluids containing hazardous gases.

The Shop Order (SO) Number, Figure Number, size and pressure rating are stamped on a nameplate attached to the valve. Please refer to the SO number when ordering parts.

### DESCRIPTION OF OPERATION

The Figure 930 allows air that is being pushed ahead of the incoming liquid to escape and ensure a complete filling of the pipeline or vessel. Once the air has been exhausted, the valve closes tight and does not re-open unless and until the system is drained and/or a negative pressure condition occurs within the pipe or vessel. It then opens to admit large quantities of air to minimize the vacuum condition.

The Figure 930 employs the Kinetic aerodynamic operating principle to ensure the valve is not prematurely blown shut by the high velocity air.

### RECEIVING AND STORAGE

Inspect the valve upon receipt for damage during shipment. Carefully unload all valves to the ground without dropping. The valve should be lifted by the body and not by the cowl.

The valves should remain in a clean, dry and weather protected area until installed. For long term storage (greater than 6 months) the rubber surfaces of the seat should be coated with a non-toxic lubricant such as "SuperLube" made by Synco Chemical. Do not expose the rubber parts to sunlight or ozone.

### INSTALLATION

The Figure 930 can be supplied in several configurations:

½" to 3" (15mm to 80mm) -  
Standard Screwed Inlet x Screwed Outlet

4" (100mm) -  
Standard Flanged Inlet x Screwed Outlet

Optional flanged inlet is available 2" (50mm) and 3" (80mm) and an outlet cowl is optional in sizes ½" (15mm) to 4" (100mm).

Optional flanged outlet is available 4" (100mm).

Consult the drawings of record to verify the configuration supplied and installed.

The valve must be installed in an upright vertical orientation, normally at a high point in the system. If installed within a vault or building, sufficient ventilation **MUST** be provided to allow air to leave and enter the valve without restriction.

An isolating valve should be installed between the valve and the pipeline or system to facilitate maintenance.

Carefully screw threaded end valves onto pipe nipple using compatible thread sealant. Tighten valve using wrench flats. **DO NOT OVERTIGHTEN.**

Flat-faced flanged valves should be mated with flat-faced flanges and full-face gaskets. If ring gaskets are used the bolt material shall be ASTM A307 Grade B (or equivalent). Higher strength bolting should only be used with full-face gaskets.

Lower heavy valves over the mating flange using slings or chains around the valve body. Lubricate the bolts or studs and insert around flange. Lightly tighten bolts until gaps are eliminated. Torque bolts in an alternating pattern in graduated steps. If leakage occurs wait 24 hours and re-torque the bolts but do not compress the gasket more than 50% or exceed bolt maximum torque rating.

**VALVE CONSTRUCTION**

The standard Figure 990 Vacuum Breaking Valve has a standard cast iron body, stainless steel float and rubber seat. Optional materials such as ductile iron body can be provided for higher working pressures. Refer to the List of Materials submitted for the order if non-standard materials were provided.

The float assembly is the only moving part and requires no lubrication or routine maintenance. Refer to Figures 1 and 2 for details of construction and parts location.

The body (1) has an inlet connection at the bottom where the valve attaches to the system and an outlet connection at the top through which air leaves and enters the valve. The outlet may be fitted with a “cowl” to minimize entry of foreign matter. The seat (3) is near the outlet end and is clamped between the body (1) and the cover (2).

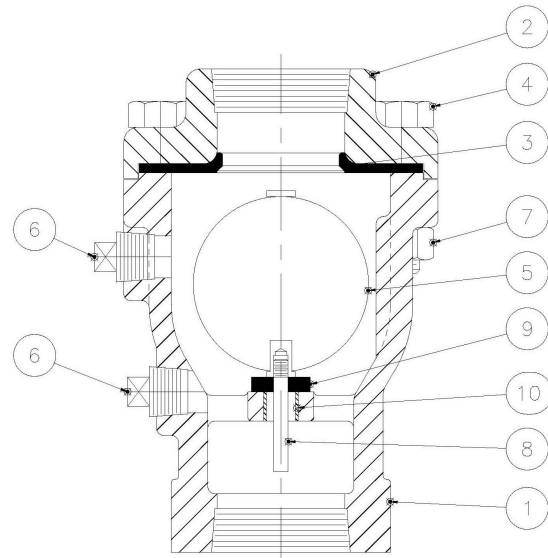

**FIGURE 1**  
**Screwed Inlet X Screwed Outlet**

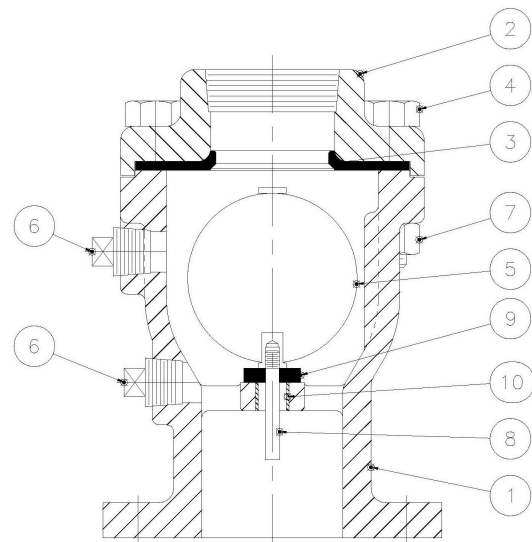

**FIGURE 2**  
**Flanged Inlet X Screwed Outlet**

**WARNING**

Removing the valve from the line or disassembling the valve while there is pressure in the valve body may result in injury or damage to the valve

**PREVENTIVE MAINTENANCE**

Figure 930 Air & Vacuum Valves require no scheduled lubrication, adjustment or preventive maintenance.

A periodic visual inspection should be performed to ensure the air inlet/outlet piping (or the cowl screen) is not obstructed and to verify there is no fluid leakage.

PARTS LIST		
Item	Name	Material
1.	Body	Cast or Ductile Iron
2.	Cover	Cast or Ductile Iron
3.	Seat	Rubber w/ SS Insert
4.	Cover Bolts	Steel
5.	Float Ball	Stainless Steel
6.	Pipe Plug	Malleable Iron
7.	Cover Nuts	Steel
8.	Float Guide	UHMW Polyethylene
9.	Cushion	Rubber
10.	Flange Bearing	Composite

## TESTING

Valve operation can be easily tested. Close the inlet isolation valve and remove or loosen the pipe plug nearest the inlet to drain the water from the valve. The float should drop as the water leaves the valve. NOTE: A ball or gate valve can be installed in place of the pipe plug to facilitate testing.

Replace or tighten the pipe plug and slowly open the inlet isolating valve. The valve should float closed and seat tightly.

## TROUBLESHOOTING

- Valve Does Not Close / Fluid Leakage  
Verify debris has not collected on the seat preventing tight closure

Verify rubber seat and metal float seating surfaces are not damaged

Verify float has buoyancy

Verify float guide is not broke or missing

- Valve Does Not Open  
Verify debris is not preventing the float from freely falling when fluid is drained from valve

Verify float guide is not broken or binding and hindering free opening

## DISASSEMBLY

While small valves may be more easily serviced by removing it from the line, all valves can be serviced while the body remains connected to the pipeline.

First ensure there is no pressure within the valve. Remove the cover bolts and nuts (4 & 7) and lift off cover (2). It may be necessary to pry the cover off.

Lift off seat (3).

Lift out the float assembly (5 & 8) and the cushion (9).

Inspect all parts for wear and damage. Minor scratches and dents in the float are normal but should not be seen in the area where the float seals against the seat. Dents in this area may cause leakage. Ensure the float guide is not cracked or broken. Replace damaged parts.

## REASSEMBLY

Clean all parts especially seating and sealing surfaces before reassembling valve. Worn parts should be replaced during re-assembly.

If necessary, screw new float guide (8) into threaded hole in float (5) but do not over tighten. Carefully place cushion (9) over guide hole in body and lower float (5) insuring float guide (8) enters guide hole and retains the cushion (9). Place seat (3) in cover (2) so that the raised lip of the seat fits inside the outlet. Carefully place cover (2) on body (1) ensuring seat is retained. Install the cover bolts (4) and nuts (7) and tighten in an alternating pattern.

Carefully introduce pressure and check for leaks.

## REPLACEMENT PARTS

Genuine replacement parts are available from your local GA Industries, Inc. representative or from the factory:

GA INDUSTRIES, INC.  
9025 Marshall Road  
Cranberry Township, PA 16066 USA  
Telephone: 724-776-1020  
Fax: 724-776-1254  
E-mail: [parts@gaindustries.com](mailto:parts@gaindustries.com)

Please have the nameplate data available when ordering parts.