

# INSTALLATION, OPERATION AND MAINTENANCE MANUAL

## FIGURE 929

### SHORT BODY AIR RELEASE VALVES FOR SEWAGE & WASTEWATER

#### TABLE OF CONTENTS

Introduction .....	1
Description of Operation .....	1
Receiving & Storage .....	1
Installation .....	1
Valve Construction .....	2
Start-Up .....	2
Preventive Maintenance .....	2
Trouble Shooting .....	2
Disassembly .....	2
Assembly .....	3
Backflushing Instructions .....	3
Order Replacement Parts .....	3
Figure 929 Drawing/Parts List .....	4
Warranty .....	5

***GA Industries, LLC***

**9025 Marshall Road**

**Cranberry Township, PA 16066 USA**

**Telephone (724) 776-1020**

**Fax (724) 776-1254**

**E-mail: [info@gaindustries.com](mailto:info@gaindustries.com)**

# INSTALLATION, OPERATION and MAINTENANCE

## Figure 929 Sewage Air Release Valves

### INTRODUCTION

This manual will provide the information to properly install, operate and maintain the valve to ensure a long service life. The Air Release Valve is ruggedly constructed to provide years of trouble-free operation with minimal maintenance.

#### CAUTION

The valve is NOT recommended for use with toxic fluids, fuels or fluids containing hazardous gases

#### CAUTION

The valve will not function if used at a pressure higher than the maximum working pressure indicated on the nameplate.

The Shop Order (SO) Number, Figure Number, size and pressure rating are stamped on a nameplate attached to the valve. Please refer to the SO number when ordering parts.

### DESCRIPTION OF OPERATION

The Figure 929 Air Release Valve is designed to automatically vent air and sewage gas that has accumulated within the valve. These valves are usually installed at high points in the system where air tends to collect. The valve as shipped is "normally open" and will vent air through its orifice at the top of the valve. The float rises when water enters the valve and closes the orifice. Air from the system accumulates in the valve forcing the water level down until the float drops and opens the venting orifice. As air is released the water level rises lifting the float and re-closing the valve.

This sequence occurs as often as necessary to release air that has collected in the valve.

### RECEIVING AND STORAGE

Inspect the valve upon receipt for damage during shipment. Carefully unload all valves to the ground without dropping.

The valves should remain in a clean, dry and weather protected area until installed. For long term storage (greater than 6 months) the rubber surfaces of the seat should be coated with a non-toxic lubricant such as "SuperLube" made by Synco Chemical. Do not expose the rubber parts to sunlight or ozone.

### INSTALLATION

The Figure 929 is standard with NPT screwed connections in 2" and 3" sizes. A flanged pipeline connection is available on special order.

Consult the drawings of record to verify the configuration supplied and installed.

The valve must be installed in an upright vertical orientation, normally at a high point in the system.

If installed outdoors, below ground in a vault or in an unheated area, adequate freeze protection must be provided. Some discharge of water may occur during operation so the valve outlet should be piped to an adequate drain.

An isolating valve should be installed between the valve and the pipeline or system to facilitate maintenance.

Carefully screw threaded end valves onto pipe nipple using compatible thread sealant. Tighten valve using wrench flats. **DO NOT OVER-TIGHTEN.**

Flat-faced flanged valves should be mated with flat-faced flanges and full-face gaskets. If ring gaskets are used the bolt material shall be ASTM A307 Grade B (or equivalent). Higher strength bolting should only be used with full-face gaskets.

Lower heavy valves over the mating flange using slings or chains around the valve body. Lubricate the bolts or studs and insert around flange. Lightly tighten bolts until gaps are

eliminated. Torque bolts in an alternating pattern in graduated steps. If leakage occurs wait 24 hours and re-torque the bolts but do not compress the gasket more than 50% or exceed bolt maximum torque rating.

### VALVE CONSTRUCTION

The standard Figure 929 Short Body Sewage Air Release Valve has a cast iron body, stainless steel float and linkage mechanism and a rubber seat. Optional materials such as ductile iron body can be provided for higher working pressures. Refer to the List of Materials submitted for the order if non-standard materials were provided.

Refer to Figure 1 for details of construction and parts location.

The body (1) has an inlet connection at the bottom where the valve attaches to the system and a smaller outlet connection at the top through which air leaves the valve.

**WARNING**  
Removing the valve from the line or disassembling the valve while there is pressure in the valve body may result in injury or damage to the valve

### PREVENTIVE MAINTENANCE

Figure 929 Sewage Air Release Valves require no scheduled lubrication or adjustment.

A periodic visual inspection should be performed to ensure the outlet piping is not obstructed and to verify there is no fluid leakage.

Depending on the nature of the fluid, sewage air valves may become clogged with sediment or grease and require periodic cleaning. To facilitate such cleaning GA Industries air valves with an "F" at the end of the Figure Number were supplied with "backflushing attachments." Refer to the backflushing instructions on Page 3 of this manual for additional information.

### TESTING

Valve operation can be easily tested. Close the inlet isolation valve and remove or loosen the pipe plug nearest the inlet to drain the water from the valve. The float should drop as the water leaves the valve. NOTE: A manual valve can be installed in place of the pipe plug to facilitate testing (valves are included with backflushing attachments).

Replace or tighten the pipe plug and slowly open the inlet isolating valve. After expelling air the valve should float close and seat tightly.

### TROUBLESHOOTING

- Valve Does Not Close / Fluid Leakage  
Verify debris has not collected on the seat preventing tight closure

Verify rubber orifice button and/or orifice seating surfaces are not damaged

Verify float has buoyancy

Verify linkage mechanism operates freely without binding or sticking

- Valve Does Not Open  
Verify debris in the valve is not preventing the float from freely falling when fluid is drained from valve

Verify linkage mechanism operates freely without binding or sticking

### DISASSEMBLY

While small valves may be more easily serviced by removing it from the line, all valves can be serviced while the body remains connected to the pipeline. A skilled technician with proper tools should perform all work. No special tools are required.

First ensure there is no pressure within the valve. Remove the cover bolts (16) and lift off cover (2) with float and linkage attached. It may be necessary to pry the cover off. Be careful not to damage or lose o-ring (10).

Remove the two spring pins (13) connecting the lever arm (11) and float arm (12) to the bracket (3). The float and linkage will be free from the cover.

Remove the spring pins (13) connecting the valve links (14) to the float arm (12). Remove the spring pin (13) from the pivot link (15) and the hex nut (8) and lock washer (9) and unscrew the float rod (21) from the float ball (20).

Remove the hex nut (8) and lockwasher (9) and unscrew the orifice button (7) from the lever arm (11).

Remove the bracket screw (5) to remove the leverage bracket (3). Using a hex socket remove the orifice (4) from the cover.

Inspect all parts for wear and damage. Minor scratches and dents in the float are normal. Some floats may contain sand for added weight but if water is detected replace the float. Carefully clean the orifice of scale. Replace damaged parts.

#### REASSEMBLY

Clean all parts especially seating and sealing surfaces before reassembling valve. Worn parts should be replaced during re-assembly.

Apply Loctite<sup>®</sup> PST thread sealant to orifice (4) and thread into cover. Torque to 22 ft-lbs (maximum).

Install bracket (3) and tighten bracket screws (5).

Thread orifice button (7) all the way into lever arm (11) and install hex nut (8) and lockwasher (9) but do not tighten. Connect the lever arm (11) and float arm (12) to the bracket (3) using two spring pins (13).

Adjust the orifice button (7) so that the end of the lever arm (11) nearest the orifice button is about 1/16" (1.6mm) farther from the cover than the opposite end when the orifice button (7) is gently resting on the orifice (4). Secure by tightening hex nut (8).

Install valve links (14) and spring pins (13) to connect the float arm (12) to the lever arm (11).

Install lock washer (9) and float rod (21) into float ball (20) and tighten. Install pivot link (15), lock washer (9) and hex nut (8) on opposite end of float rod (19) and tighten. Attach pivot link (15) to float arm (12) using spring pin (13).

Verify free movement of linkage mechanism and that the orifice button (7) presses against the orifice (4) when the float is lifted and pulls away when it is allowed to fall.

Lubricate and place o-ring (10) in cover (2) and carefully place cover (2) on body (1) ensuring o-ring is retained. Install the cover bolts (16) and tighten in an alternating pattern.

Carefully introduce pressure and check for leaks

#### BACKFLUSHING INSTRUCTIONS

Follow all local cross-connection and safety codes and regulations!

To determine if a GA Industries sewage air valve is in need of cleaning or backflushing:

- Close the inlet isolating valve then slowly open the ½" flushing ball valve (if installed) or slowly remove the pipe plug at the top of air valve to relieve internal pressure.
- Open the 1" blow off ball valve (if installed) or remove the pipe plug near the bottom. Liquid should freely drain from the valve body. If it does not, then the valve is likely in need of cleaning/backflushing.

To clean a GA Industries sewage air release valve equipped with backflushing attachments:

- Close the inlet isolating valve and then slowly open the ½" flushing valve to relieve internal pressure.
- Open the 1" blow off valve
- Connect the ½" flushing valve to a pressurized source of clean water using the rubber hose provided with the backflushing attachments.
- Introduce flushing water until liquid runs freely from the blow off valve.
- Shut off and disconnect the supply of clean water and close the blow off and flushing valves.
- Slowly open the inlet isolating valve. The air release valve should exhaust air and then close tightly

#### REPLACEMENT PARTS

Genuine replacement parts are available from your local GA Industries, LLC representative or from the factory:

GA INDUSTRIES, LLC  
9025 Marshall Road  
Cranberry Township, PA 16066 USA  
Telephone: 724-776-1020  
Fax: 724-776-1254  
E-mail: [parts@gaindustries.com](mailto:parts@gaindustries.com)

Please have the nameplate data available when ordering parts.

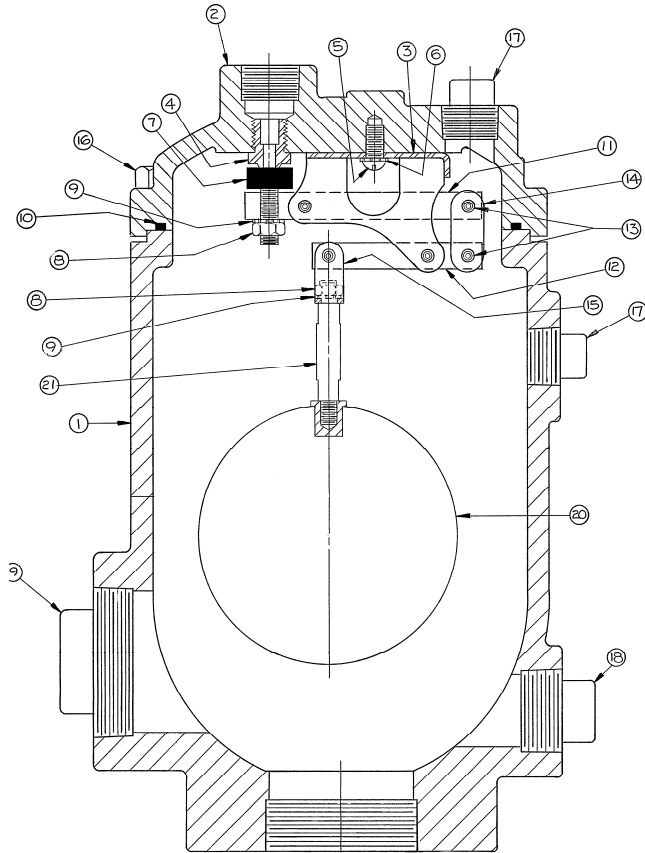

**PARTS LIST**

1. Body
2. Cover
3. Leverage Bracket
4. Orifice
5. Bracket Screw
6. Lock Washer
7. Orifice Button
8. Hex Nut
9. Lock Washer
10. O-Ring
11. Lever Arm
12. Float Arm
13. Spring Pin
14. Valve Link
15. Pivot Link
16. Cover Bolt
17. ½" Pipe Plug
18. 1" Pipe Plug
19. 2" Pipe Plug
20. Float Ball
21. Float Rod

Figure 1

## WARRANTY

GA Industries, LLC (Seller) warrants to the original Buyer that all products delivered hereunder shall be free from defects in manufacture for a period of one year from the date of delivery, provided that such products are installed, used, operated, adjusted and serviced only in a proper and appropriate manner and in strict accordance with any instructions relating thereto furnished to Buyer by Seller. In no event shall the foregoing warranty extend to any products in any way caused or allowed to be, or installed, operated or used in such a manner as to be subject or exposed to conditions of misuse, abuse or accident.

Products not manufactured by Seller shall be warranted only to the extent of warranty to Seller.

*The foregoing warranty is exclusive and lieu of any and all other warranties, expressed or implied. No warranty of merchantability, no implied warranty of fitness for any particular purpose, and no implied warranty arising by usage of trade, course of dealing or course of performance is given by Seller or shall arise by or in connection with this sale and/or the Seller's and/or Buyer's conduct in relation thereto or to each other, and in no event shall Seller be liable on any such warranty with respect to any product.*

Liability of the Seller under or in connection with this sale and/or the foregoing warranty shall be limited, at the sole option of the Seller, to one of repair or, replacement of, or a refund of the purchase price of any products or part thereof with respect to which Seller receives. Promptly after Buyer's discovery of any alleged defect and prior to the expiration of the one-year warranty period as provided above, notice, in writing, from Buyer of Buyer's claim of defect, and which shall be returned to Seller by Buyer, as provided herein, promptly after Buyer's discovery of such alleged defect and which shall be determined by the Seller to have proved defective within the one-year warranty period provided above, failure by Buyer so to notify Seller and return such products to Seller after Buyer's discovery of such alleged defect shall constitute a waiver by Buyer of any and all claims of any kind with respect there to. Any products returned by Buyer to Seller under the foregoing terms shall be returned to Seller's place of business freight prepaid, accompanied or preceded by Buyer's particularized statement of the claimed defect. The risk of loss and freight charges to and from Seller in connection with any returned products shall be borne by Buyer; but Seller shall bear such additional freight charges arising in connection with any returned products ultimately determined by Seller to be defective under the terms of the foregoing warranty, the cost of repair or replacement (if any) of such products, and the risk of loss or damage while such products are in Seller's possession at its place of business. The foregoing remedy shall constitute the sale and exclusive remedy of the Buyer under or in connection with this sale and/or warranty of the Seller. Except as specifically provided herein, Seller shall not be responsible or liable for any costs, expenses or damages of Buyer in connection with any removal, repair or replacement (including any attempts or actions relating thereto) of any allegedly defective products, and no charge or setoff of any kind of Buyer relating thereto shall be made against the Seller without prior and specific written approval of Seller.

*In no event shall Seller be responsible or liable for any special, indirect, incidental or consequential damages arising in any way in connection with any products or this sale.*

The agreement of Seller to sell its products is expressly conditioned upon the Buyer's assent to, and Seller agrees to sell its products only upon, all terms and conditions set forth in the Seller's Terms and Conditions of Sales. Failure to comply with terms will void warranty. Buyer's acceptance of any products provided under this sale constitutes such assent.



9025 Marshall Road  
Cranberry Township, PA 16066 USA  
Phone: 724-776-1020 • Fax: 724-776-1020 • E-mail: [info@gaindustries.com](mailto:info@gaindustries.com)