

INSTALLATION, OPERATION AND MAINTENANCE MANUAL

LUDLOW SERIES FIGURE 340-W 3” to 20”

Lever & Weight Swing Check Valves

TABLE OF CONTENTS

Introduction	1
Description of Operation	1
Receiving & Storage	1
Installation	1
Valve Construction	1
Start-Up	1
Preventive Maintenance	2
Trouble Shooting	2
Disassembly	2
Assembly	2
Assembly Drawing/Parts Location	3
Warranty	4

GA Industries, LLC

9025 Marshall Road

Cranberry Township, PA 16066 USA

Telephone (724) 776-1020

Fax (724) 776-1254

E-mail: info@gaindustries.com

INSTALLATION, OPERATION and MAINTENANCE

Figure 340-W Swing Check

INTRODUCTION

This manual will provide the information to properly install, operate and maintain the valve to ensure a long service life. The Figure 340-W Lever & Weight Swing Check Valve is ruggedly constructed to provide years of trouble-free operation with minimal maintenance.

CAUTION

The valve is NOT recommended for use with toxic or highly corrosive fluids, fuels or fluids containing hazardous gases

The Shop Order (SO) Number, Figure Number, size and pressure rating are stamped on a nameplate attached to the valve. Please refer to the SO number when ordering parts.

DESCRIPTION OF OPERATION

The Figure 340-W Lever & Weight Swing Check Valve is designed to permit flow in one direction and close to prevent reverse flow. The valve opens when the inlet pressure exceeds the outlet pressure. The degree of opening depends on the fluid velocity through the valve. The valve will swing closed as fluid velocity decreases and be fully seated before flow reversal precluding slam and bang.

RECEIVING AND STORAGE

Inspect the valve upon receipt for damage during shipment. Carefully unload all valves to the ground without dropping.

The valves should remain in a clean, dry and weather protected area until installed. For long term storage (greater than 6 months) the rubber surfaces of the seat should be coated with a non-toxic lubricant such as "SuperLube" made by Synco Chemical. Do not expose the rubber parts to sunlight or ozone.

INSTALLATION

The Figure 340-W is standard with ANSI Class 125 flanged connections.

Consult the drawings of record to verify the configuration supplied and installed.

Prior to installation ensure all debris, packing material or other foreign material has been removed from both ports.

The valve can be installed in a horizontal or vertical (upward flow direction) pipe. In either case the counterweight arm must be horizontal when the valve is closed.

Install the valve in the proper flow direction.

If installed outdoors, below ground in a vault or in an unheated area, adequate freeze protection must be provided.

Adequate isolating valves should be installed between the valve and the pipeline or system to facilitate maintenance.

The valve is not designed to support adjacent equipment, piping loads should not be imposed on the valve and large valves should be properly supported. Ensure mating flanges are square and parallel to the valve flanges before tightening flange bolts.

Flat-faced flanged valves should be mated with flat-faced flanges and full-face gaskets. If ring gaskets are used the bolt material shall be ASTM A307 Grade B (or equivalent). Higher strength bolting should only be used with full-face gaskets.

Lower heavy valves using slings or chains around the valve body and/or the lifting eye. Lubricate the bolts or studs and insert around flange. Lightly tighten bolts until gaps are eliminated. Torque bolts in an alternating pattern in graduated steps. If leakage occurs wait 24 hours and re-torque the bolts but do not compress the gasket more than 50% or exceed bolt maximum torque rating.

VALVE CONSTRUCTION

The standard Figure 340-W Lever & Weight Swing Check Valve has a ductile iron body and cover, bronze or stainless steel body seat, stainless steel hinge shaft and ductile iron disc with a rubber disc seat. Refer to the List of Materials submitted for the order if non-standard materials were provided.

Refer to Page 5 for details of construction and parts location.

START-UP

The valve does not require any calibration or adjustment prior to start-up.

The valve should smoothly swing open as flow through the valve increases. The amount of opening depends on the flow through the valve and can be observed by watching the counterweight arm. The valve is "full ported" at about 22 degrees of swing but can swing open as much as 60 degrees.

Observe the valve's closure. If the valve was less than 60 degrees open and the closure was smooth and quiet then move the counterweight farther out on the arm. Repeat these steps to the point where the valve opens to the extent possible but still closes quietly.

If the counterweight is at the end of the arm yet the valve does not close quietly it may be necessary to add another counterweight. This is common in vertical installations.

PREVENTIVE MAINTENANCE

Figure 340-W Lever & Weight Swing Check Valves require no scheduled lubrication, adjustment or preventive maintenance.

A monthly inspection should be performed for the first 6 months of operation to ensure the valve is functioning properly and there is no external fluid leakage or audible evidence of water leaking backwards through the closed valve.

Thereafter, a quarterly visual inspection should be performed.

TROUBLESHOOTING

- Shaft packing leakage
Tighten packing gland nuts equally just enough to stop leakage, no more than ½ turn at a time. Replace packing if necessary.
- Leakage past seat when closed
Inspect valve for debris, clean
Inspect seating surfaces for damage, replace as necessary
- Leakage past cover or flange gaskets
Tighten cover or flange bolts
- Disc oscillating when open
Adjust counterweight inward along arm
- Valve slams upon closing
Adjust counterweight outward along arm
Ensure shaft packing is not too tight

WARNING

Removing the valve from the line or disassembling the valve while there is pressure in the valve body may result in injury or damage to the valve

WARNING

Follow all applicable safety regulations and codes and read and understand all instructions before undertaking disassembly.

DISASSEMBLY

All Figure 340-W valves can be serviced while the body remains connected to the pipeline. A skilled technician should perform all work. No special tools are required.

First ensure there is no pressure within the valve and operating equipment is tagged and locked out. Refer to page 5 for parts identification.

It is not necessary to disassemble the entire valve to remove the shaft packing, follow steps 1 to 4 and 4a.

1. Ensure there is no pressure within the valve and operating equipment is locked out.
2. Mark the position of the counterweight(s) on the counterweight arm. Loosen counterweight arm set screw (30A) and slide the counterweight arm (30) and weight (31) off the shaft (11). In large valves it may be necessary to first loosen the counterweight set screws (31A) and remove the counterweight(s) from the arm.
3. Loosen and remove the gland bolts (16) and slide the glands (15) off the shaft (11) on both sides of the valve.
4. Remove the shaft packing (17) from both sides of the valve.
5. Remove the cover nuts (10) and lift off cover (9). It may be necessary to carefully pry the cover off. Be careful not to damage or lose the cover gasket (8) unless it is to be replaced.
6. Remove the shaft lock pin (18) and while supporting the disc arm assembly pull the shaft (11) out of the valve.
NOTE: It may be necessary to tap on the end of the shaft to remove it from the disc arm.
NOTE: The outer bushing (14) and disc arm key (19) should come out with the shaft. Be careful not to lose the disc arm key. After the shaft is out, remove the inner bushing (13) from the opposite side.
7. Carefully lift the disc arm assembly out of the body. Remove the disc nut pin (6B), disc nut (6) and disc nut washer (6A).
8. Disc seat is vulcanized to the disc and cannot be removed. If the rubber disc seat is damaged, the entire disc with vulcanized seat must be replaced.

Inspect all parts for wear and damage. Replace damaged parts.

ASSEMBLY

The valve is reassembled by reversing the disassembly sequence with consideration of the following:

- 1a. Clean and polish all machined bearing and sealing surfaces. Apply a light coat of lubricant to assist in the assembly.

- 2a. Ensure the disc arm key slides inside the disc arm shaft before installing the shaft lock pin (18). Ensure the shaft lock pin is centered in the groove provided for it on the shaft. Tighten the shaft lock pin (18) until the shaft will not turn then back off 1/2 turn.
- 3a. Lift the disc assembly several times to ensure free closure with no metal-to-metal contact.
- 4a. Install the inner and outer bushings then install the shaft packing. Wrap the packing around the shaft and cut on a 45-degree angle, staggering the cuts with each ring.
- 5a. Tighten gland bolts evenly until packing is slightly compressed. After pressure has been introduced into the valve, re-tighten evenly until leakage stops.
- 6a. Ensure cover gasket sealing surfaces are clean and apply a thin coat of Permatex™ #2 to both surfaces. Tighten cover nuts in an alternating pattern. Re-tighten as needed after pressure has been introduced.

Part No.	Part Name	Std. Material
1.	Body	Ductile Iron
2.	Body Seat	Bronze or SS
3.	Disc w/Seat	Ductile Iron/Buna N
4.	Disc Arm	Ductile Iron
6.	Disc Nut	Brass
6A.	Disc Nut Washer	Brass
6B.	Disc Pin	Stainless Steel
8.*	Cover Gasket	Composition
9.	Cover	Ductile Iron
10.	Cover Stud w/Nut	Steel
10A.	Eye Bolt	Steel
11.	Shaft	Stainless Steel
13.	Inner Bushing	Bronze
14.	Outer Bushing	Bronze
15.	Gland	Ductile Iron
16.	Gland Bolt	Steel
17.*	Packing	Teflon
18.	Shaft Lock Pin	Steel
19.	Disc Arm Key	Stainless Steel
30.	Counterweight Arm	Cast Iron/Steel
30A	Counterweight Arm Set Scr.	Steel
31.	Counterweight	Cast Iron or Steel
31A.	Counterweight Set Screw	Steel

- Recommended Spares

REPLACEMENT PARTS

Genuine replacement parts are available from your local GA Industries, LLC representative or from the factory:

GA INDUSTRIES, LLC
 9025 Marshall Road
 Cranberry Township, PA 16066 USA
 Telephone: 724-776-1020
 Fax: 724-776-1254
 E-mail: parts@gaindustries.com

Please have the nameplate data available when ordering parts. Identify needed part(s) by Shop Order (SO) Number, Figure 340-W, valve size and Part No.

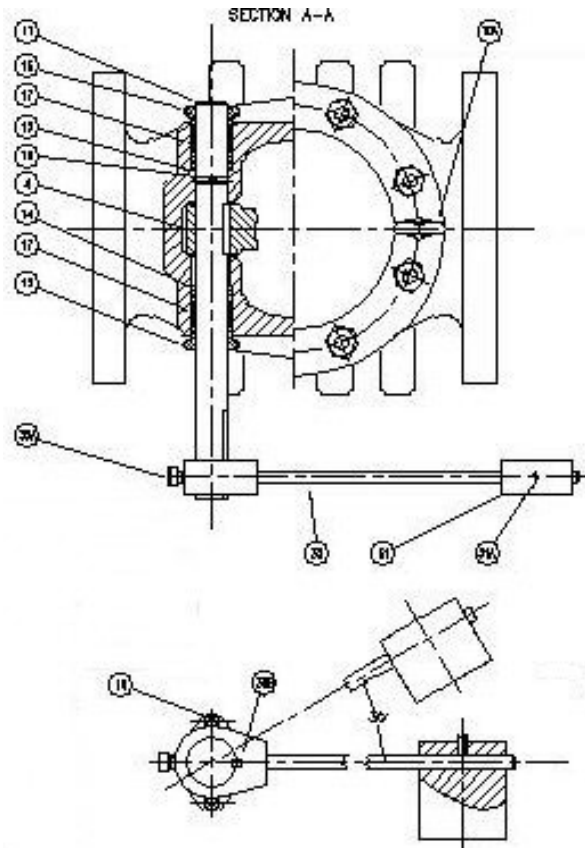
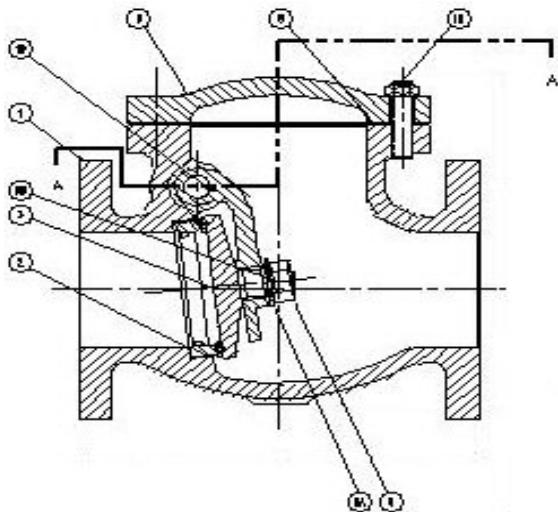

WARRANTY

GA Industries, LLC (Seller) warrants to the original Buyer that all products delivered hereunder shall be free from defects in manufacture for a period of one year from the date of delivery, provided that such products are installed, used, operated, adjusted and serviced only in a proper and appropriate manner and in strict accordance with any instructions relating thereto furnished to Buyer by Seller. In no event shall the foregoing warranty extend to any products in any way caused or allowed to be, or installed, operated or used in such a manner as to be subject or exposed to conditions of misuse, abuse or accident.

Products not manufactured by Seller shall be warranted only to the extent of warranty to Seller.

The foregoing warranty is exclusive and lieu of any and all other warranties, expressed or implied. No warranty of merchantability, no implied warranty of fitness for any particular purpose, and no implied warranty arising by usage of trade, course of dealing or course of performance is given by Seller or shall arise by or in connection with this sale and/or the Seller's and/or Buyer's conduct in relation thereto or to each other, and in no event shall Seller be liable on any such warranty with respect to any product.

Liability of the Seller under or in connection with this sale and/or the foregoing warranty shall be limited, at the sole option of the Seller, to one of repair or, replacement of, or a refund of the purchase price of any products or part thereof with respect to which Seller receives. Promptly after Buyer's discovery of any alleged defect and prior to the expiration of the one-year warranty period as provided above, notice, in writing, from Buyer of Buyer's claim of defect, and which shall be returned to Seller by Buyer, as provided herein, promptly after Buyer's discovery of such alleged defect and which shall be determined by the Seller to have proved defective within the one-year warranty period provided above, failure by Buyer so to notify Seller and return such products to Seller after Buyer's discovery of such alleged defect shall constitute a waiver by Buyer of any and all claims of any kind with respect thereto. Any products returned by Buyer to Seller under the foregoing terms shall be returned to Seller's place of business freight prepaid, accompanied or preceded by Buyer's particularized statement of the claimed defect. The risk of loss and freight charges to and from Seller in connection with any returned products shall be borne by Buyer; but Seller shall bear such additional freight charges arising in connection with any returned products ultimately determined by Seller to be defective under the terms of the foregoing warranty, the cost of repair or replacement (if any) of such products, and the risk of loss or damage while such products are in Seller's possession at its place of business. The foregoing remedy shall constitute the sale and exclusive remedy of the Buyer under or in connection with this sale and/or warranty of the Seller. Except as specifically provided herein, Seller shall not be responsible or liable for any costs, expenses or damages of Buyer in connection with any removal, repair or replacement (including any attempts or actions relating thereto) of any allegedly defective products, and no charge or setoff of any kind of Buyer relating thereto shall be made against the Seller without prior and specific written approval of Seller.

In no event shall Seller be responsible or liable for any special, indirect, incidental or consequential damages arising in any way in connection with any products or this sale.

The agreement of Seller to sell its products is expressly conditioned upon the Buyer's assent to, and Seller agrees to sell its products only upon, all terms and conditions set forth in the Seller's Terms and Conditions of Sales. Failure to comply with terms will void warranty. Buyer's acceptance of any products provided under this sale constitutes such assent.

GA Industries, LLC.
A Zurn Company



MANUFACTURERS OF
GOLDEN ANDERSON VALVES

9025 Marshall Road
Cranberry Township, PA 16066 USA
Phone: 724-776-1020 • Fax: 724-776-1020 • E-mail: info@gaindustries.com