



Rubber Flapper Check Valve

Operation, Maintenance and Installation Manual

GENERAL

The Rubber Flapper Check Valve has been designed to give years of trouble-free operation. This manual will provide you with the information needed to properly install and maintain the valve and to ensure a long service life. The valve is opened by the fluid flow in one direction and closes automatically to prevent flow in the reverse direction. An optional backflow actuator may be mounted on the bottom of the valve to allow manual backflow through the valve in the reverse direction.

The valve is of the swing check type utilizing an angled seat and fully encapsulated, resilient disc. It is capable of handling a wide range of fluids including flows containing suspended solids. The Size, Flow Direction, Maximum Working Pressure, and Series Number are stamped on the nameplate for reference.

CAUTION:

Do not use valve for line testing at pressures higher than nameplate rating or damage to valve may occur.

The “Maximum Working Pressure” is the non-shock pressure rating of the valve at 150° F. The valve is not intended as an isolation valve for line testing above the valve rating.

RECEIVING AND STORAGE

Inspect valves upon receipt for damage in shipment. Unload all valves carefully to the ground without dropping. Do not allow lifting slings or chains to come in contact with backflow actuator or seat area; use eye bolts or rods through the flange holes on large valves.

Valves should remain crated, clean and dry until installed to prevent weather related damage. For long term storage greater than six months, the rubber surfaces of the disc should be coated with a thin film of FDA approved grease such as Lubriko #CW-606. Do not expose disc to sunlight or ozone for any extended period.

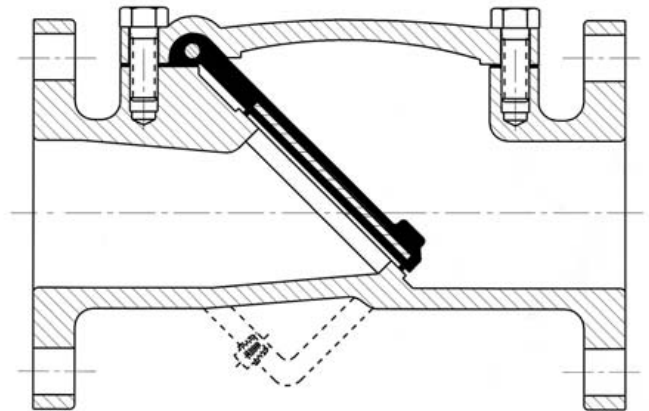

FIGURE #1 Rubber Flapper Check Valve

OPERATION

The valve is designed to prevent reverse flow automatically. During system flow conditions, the movement of the fluid forces the disc to the open position allowing 100% un-restricted flow area through the valve. Under reverse flow conditions, the disc automatically returns to the closed position to prevent reverse flow.

An optional backflow actuator assembly is available which can be easily installed in the field. (See Backflow Actuator Installation instructions on page 4.) The actuator is not designed to operate at the valves Maximum Working Pressure rating. Therefore, prior to using the actuator, close the pump isolation valve and bleed off line pressure. To operate, turn the handle clockwise. This will open the valve disc allowing backflow through the valve. The handle should turn easily. When resistance is felt, the disc has reached its body stop and is in the full open position.

WARNING:

Relieve line pressure before using back flow actuator or damage may occur.

Upon completion of the backflushing operation, turn the handle counter-clockwise and the valve will automatically return to the closed position. Lock the actuator in the closed position with the jam nut provided. The system is again ready for normal operation.



INSTALLATION

Correct installation of the Rubber Flapper Check Valve is important for proper operation. It may be installed in either horizontal or vertical (flow-up) applications. However, when horizontal, the valve must be installed with the nameplate facing up. In all installations, the flow arrow cast in the valve cover must be pointed in the direction of flow during normal system operation.

Flanged Ends: Flanged valves should only be mated with flat-faced pipe flanges equipped with full-face resilient gaskets. The valve and adjacent piping must be supported and aligned to prevent cantilevered stress on the valve. Once the flange bolts or studs are lubricated and inserted around the flange, tighten them uniformly hand tight. The torquing of the bolts should then be done in graduated steps using the cross-over tightening method. Recommended lubricated torques for use with resilient gaskets (75 durometer) are given in Table 1. If leakage occurs, allow gaskets to absorb fluid and check torque and leakage after 24 hours. Do not exceed bolt rating or extrude gasket.

VALVE SIZE (IN)	BOLT DIA (IN)	RECOM. TORQUE (FT-LBS)	MAX. TORQUE (FT-LBS)
3"	5/8"	30	80
4"	5/8"	30	80
6"	3/4"	35	140
8"	3/4"	45	140
10"	7/8"	50	200
12"	7/8"	70	200
14"	1"	90	300
16"	1"	90	300
18"	1-1/8"	110	400
20"	1-1/8"	110	400
24"	1-1/4"	160	600

TABLE #1 Flange Bolt Torques

CAUTION:

The use of ring gaskets or excessive bolt torque may damage valve flanges.

VALVE DESIGN

The standard Rubber Flapper Check Valve is constructed of rugged cast ductile iron with a rubber encapsulated disc. See the specific Materials List submitted for the order if other than standard cast ductile iron construction. The disc is the only moving part assuring long life with minimal maintenance. The general details of construction are illustrated in Figure 2. The body (1) is flanged for connection to the pipeline with an open top sealed with a cast cover (2). The disc (3) is retained by the cover.

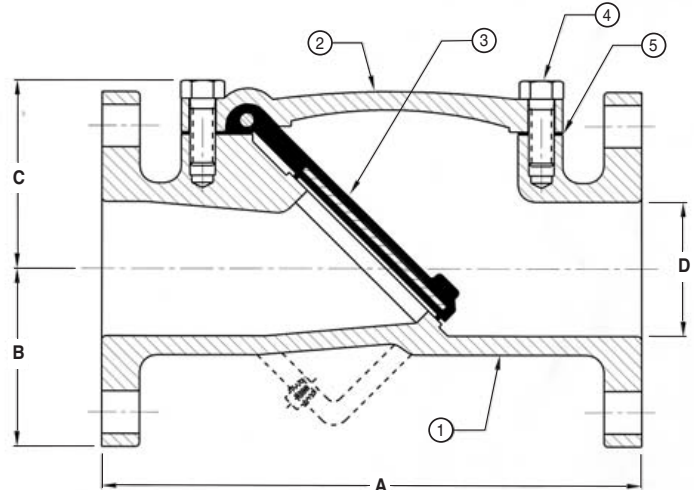

FIGURE #2 Check Valve Construction

Material Call Out

Part Number	Part Name	Material
1	Body	Cast Ductile Iron (65-45-12)
2	Cover	Cast Ductile Iron (65-45-12)
3	Disc	DI/Steel-Nitrite Covered
4	Cover Bolt	Steel - Grade #5
5	Cover Gasket	Commercial Grade Rubber

MAINTENANCE

The Rubber Flapper Check Valve requires no scheduled lubrication or maintenance. For service or inspection, the valve can be serviced without removal from the line.

Valve Inspection: If inspection of the valve is required, follow the disassembly instructions provided on page 3.

TROUBLESHOOTING

Several problems and solutions are presented below to assist you in troubleshooting the valve assembly in an efficient manner.

- **Leakage at Bottom Actuator**

Remove line pressure and exercise actuator. If leak persists, replace seals in actuator; see the Backflow Actuator Seal Replacement Procedure on page 4.

- **Leakage at Flanges**

Tighten bolts, replace gasket.

- **Valve Leaks when closed**

Inspect disc for damage and replace. Inspect metal seating surface; clean if necessary.

- **Valve does not open**

Check for obstruction in valve; see Disassembly procedure on page 4. Operating pressure may be less than cracking pressure if less than 0.5 psig; review application with factory.

DISASSEMBLY

The valve can be disassembled without removing it from the pipeline. Or for convenience, the valve can be removed from the line. All work on the valve should be performed by a skilled mechanic with proper tools and a power hoist for larger valves. Disassembly may be required to inspect the disc for wear or the valve for deposits.

WARNING:

The line must be drained before removing the cover or pressure may be released causing bodily harm.

1. Relieve pressure and drain the pipeline. Refer to figure 2 on page 2. Remove the cover bolts (4) on top cover.
2. Pry cover (2) loose and lift off valve body.
3. Remove disc (3) and inspect for cracks, tears or damage in rubber sealing surface.
4. Clean and inspect parts. Replace worn parts as necessary and lubricate parts with FDA grease such as Lubriko #CW-606.

RE-ASSEMBLY

All parts must be cleaned. Gasket surfaces should be cleaned with a stiff wire brush in the direction of the serrations or machine marks. Worn parts, gaskets and seals should be replaced during reassembly.

1. Lay disc (3) over seat with beaded seating surface directed down toward machined seat.
2. Lay cover gasket (5) and cover (2) over bolt holes and disc hinge.
3. Insert lubricated bolts (4) noting that the bolts in the hinge area are longer than the other cover bolts.
4. Cover bolts should be torqued to the following specifications during assembly.

Size	Torque (FT-LBS)
3/8"	25
1/2"	60
5/8"	120
3/4"	200
7/8"	200
1"	300

TABLE #2 Valve Cover Bolt Torques

PARTS AND SERVICE

Parts and service are available from your local representative or the factory. Make note of the Valve Size, Series No., and Serial No. located on the valve nameplate and contact:

GA Industries Inc.

9025 Marshall Road
Cranberry Twp. PA, 16066-3696
Phone: (724) 776-1020
Fax: (724) 776-1254

Backflow Actuator Field Installation and Maintenance (Optional)

Backflow Actuator Field Installation:

The backflow actuator is supplied as an optional assembly from the factory.

WARNING: Removal of the bottom plug while under pressure may cause bodily harm.

1. Depressurize and drain pipeline.
2. Remove the pipe plug in the bottom boss of the valve.
3. Inspect the backflow rod and place in the non-extended position. (The rod should extend about 1" past the end of the brass bushing.) Apply Teflon thread sealant to brass threads.
4. Insert the threaded end of the assembly into the valve boss. Slowly turn the assembly into the boss taking care not to cross-thread the bushing. Continue turning the assembly into the valve for a tight fit.

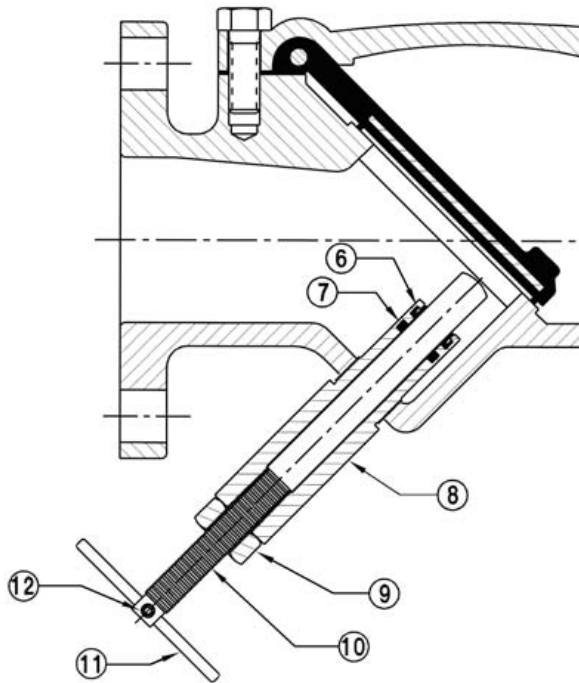

FIGURE #3 Backflow Actuator Assembly

Backflow Actuator Seal Replacement:

There are two parts (6 & 7) on the backflow actuator that are subject to wear. To replace the seals, the pipeline must first be depressurized and drained. Next, remove the backflow assembly from the valve by turning the Back Flow Tube (8) counter-clockwise. Disassemble the actuator as follows:

1. Remove the Set Screw (12) with an Allen wrench.
2. Remove the T-Handle (11) and jam nut (9) from the rod (10).
3. Remove the rod (10) from the tube (8) by screwing in the rod fully clockwise and pull the rod through the valve end of the tube (8).
4. Lubricate new seals with FDA approved grease such as Lubriko #CW-606 and install in the bushing end grooves.
5. Clean, lubricate and reinstall rod in bushing.
6. Re-install jam nut (9) and rod handle (11).
7. Install set screw (12) on handle (11).
8. Apply Teflon thread sealant to bushing and carefully thread into valve taking care not to cross-thread the bushing.

Part Number	Part Name	Material
6	*Rod Wiper	Urethane Rubber
7	*Rod Seal	Buna - N Rubber
8	Back Flow Tube	Brass ASTM B16, A360
9	Back Flow Jam-Nut	Brass ASTM B16, A360
10	Back Flow Rod	St. Steel 304, ASTM, A276
11	Back Flow Rod Handle	St. Steel 304, ASTM, A276
12	Back Flow Rod Set Screw	St. Steel 304

*Recommended spare part.

TABLE #3 Backflow Actuator Parts List

GA Industries Inc.



GA Industries Inc.

9025 MARSHALL ROAD • CRANBERRY TOWNSHIP, PA 16066-3696 USA

PHONE: (724) 776-1020 • FAX: (724) 776-1254 • WEB SITE: www.gaindustries.com • E-MAIL: ga@gaindustries.com