

# KINETIC AIR/VACUUM VALVE

10" and 16" Flanged Inlet Size  
Standard Outlet Cowl



FIG. 930

## AIR/VACUUM VALVE WITH OUTLET COWL

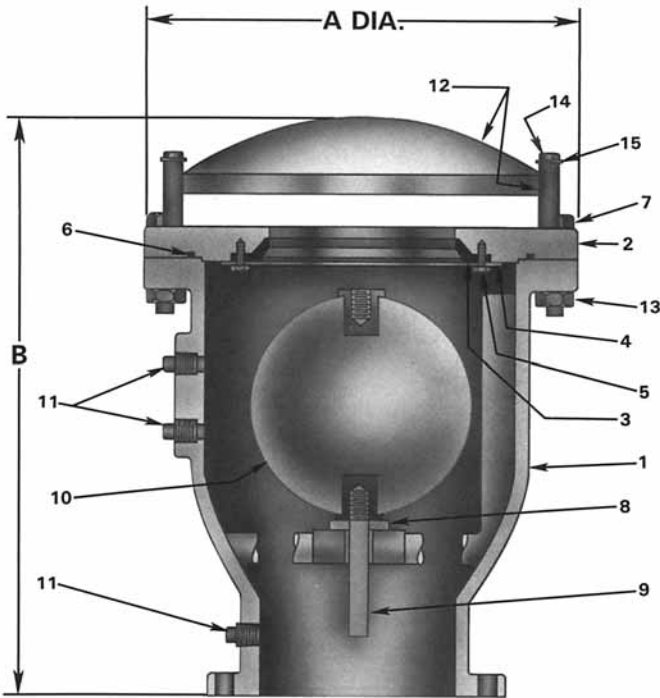

FIG. 930 Flange Dimension Per ANSI B16.1 Class 125 (CL.250 Optional)

## GENERAL DIMENSIONS

VALVE SIZE	A (DIAMETER)	B (HEIGHT)	WEIGHT (LBS.)
10"	23-1/2"	33"	475
12"	27-1/2"	39-7/8"	625
14"	27-1/2"	39-7/8"	675
16"	33-1/2"	48"	875

## ENGINEERING SPECIFICATION

The Air/Vacuum Valve shall employ the KINETIC principle to automatically exhaust large quantities of air during the filling of a pipeline or vessel and to allow air to re-enter during draining or when a negative pressure occurs. Valves shall be designed to exhaust air at up to sonic velocity without blowing shut.

The inlet shall be the nominal size of the valve and the outlet shall be the same size as the inlet. The float shall be spherical, be capable of withstanding a test pressure of 1000 psig and shall seal against a renewable resilient seat.

The body and cover shall be constructed of cast iron conforming to ASTM A126 Class B. The float shall be made of stainless steel. Unless otherwise specified, a protective cowl shall be provided on the outlet.

KINETIC Air/Vacuum Valves shall be as manufactured by GA Industries, Inc., their Figure 930 (formerly Figure GH21K).

## PARTS LIST

1. BODY - Cast Iron A126 Class B
2. COVER - Cast Iron A126 Class B
3. SEAT - Buna-N
4. FOLLOWER RING - 304 Stainless Steel
5. SEAT SCREWS - 18-8 Stainless Steel
6. O-RING - Buna-N
7. COVER BOLTS - Steel Grade 2
8. CUSHION - Urethane
9. FLOAT GUIDE - 316 Stainless Steel
10. FLOAT BALL - 316 Stainless Steel
11. PIPE PLUG - Malleable Iron
12. COWL ASSEMBLY - Steel (Commercial)
13. COVER NUTS - Steel Grade 2
14. COWL BOLTS - Steel Grade 2
15. COWL WASHER - Steel (Commercial)

## ENGINEERING DATA

### Kinetic Operating Principle

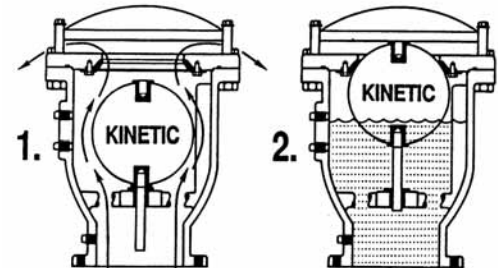

1. During the exhausting sequence, the air flowing around the buoy ball produces a resultant downward force which maintains the ball in the open position.
2. The buoyant force of the ball will seal the exhaust orifice when water reaches the ball.

### Pressure Rating:

- CL.125 FLG Inlet Body rated to 200 psi WOG; tested to 300 psi.
- CL.250 FLG Inlet Body rated to 400 psi WOG; tested to 600 psi.
- Ball Float tested to 1000 psi.

### Connections:

- CL.125 FLG Inlet x Outlet Cowl - Standard
- CL.250 FLG Inlet x Outlet Cowl - Optional

### Options:

- For Optional CL.125 FLG Outlet, specify 930-J.

FOR SIZING AND LOCATING,  
SEE PAGES 36-37.