

SHORT BODY

Sewage Air Release Valve



FIG. 929

SEWAGE AIR RELEASE

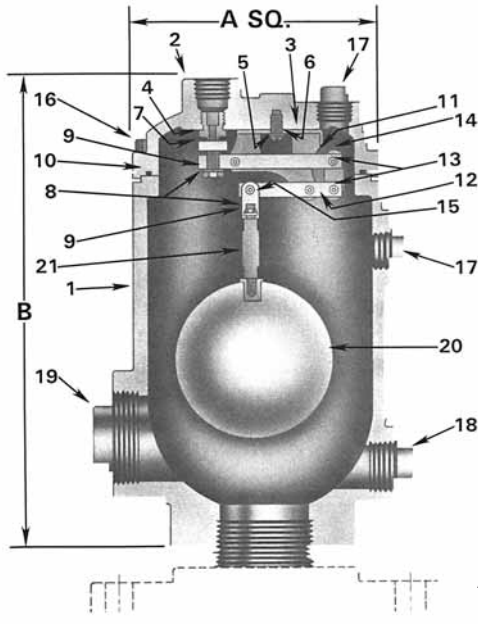

FIG. 929

GENERAL DIMENSIONS

VALVE (INLET)	VALVE (OUTLET)	A (SQUARE)	B (HEIGHT)	WEIGHT (LBS.)
2" NPT	1/2" NPT	6-3/8"	12"	40
3" NPT		6-3/8"	14"	60
4" FLG				

ENGINEERING SPECIFICATION

The "Short Body" Sewage Air Release Valve shall be float operated and shall employ a compound lever mechanism to enable the valve to automatically release accumulated air and gases from a sewage pipeline while the system is pressurized and operating.

The Air Release Valve shall close drop tight, incorporating an adjustable Buna-N orifice button. All internal metal parts shall be of stainless steel. The linkage/lever mechanism shall be able to be removed from the valve without disassembly of the mechanism. The float shall be stainless steel and be capable of withstanding a 1000 PSIG test pressure.

The body and cover shall be of cast iron conforming to ASTM A126 Class B. Inlet connection shall be 2" or 3" NPT, or 4" FLG, as required. Outlet connection shall be 1/2" NPT. Maximum height (without attachments) shall be 12" (2" and 3" size), 14" (4" size).

When specified, the valve shall be supplied with a "Flushing Attachment" consisting of: bronze shut-off valves, quick-connect couplings and rubber hose, for back washing with clear water.

The "Short Body" Sewage Air Release Valve shall be as manufactured by GA Industries, Inc., their Figure 929 (formerly Figure SARS-3 or SARS-5).

PARTS LIST

1. BODY - Cast Iron A126 Class B
2. COVER - Cast Iron A126 Class B
3. LEVERAGE BRACKET - 316 Stainless Steel
4. ORIFICE - 316 Stainless Steel
5. BRACKET SCREWS - 18-8 Stainless Steel
6. BRACKET LOCKWASHER - 18-8 Stainless Steel
7. ORIFICE BUTTON - Buna-N/18-8 Stainless Steel
8. HEX NUT - 18-8 Stainless Steel
9. LOCKWASHER - 81-8 Stainless Steel
10. O-RING - Buna-N
11. LEVER ARM - 316 Stainless Steel
12. FLOAT ARM - 316 Stainless Steel
13. COILED SPRING PIN - 302 Stainless Steel
14. VALVE LINK (Air Release) - 316 Stainless Steel
15. PIVOT LINK - 316 Stainless Steel
16. COVER BOLTS - Steel Grade 2
17. PIPE PLUG 1/2" NPT - Steel (Commercial)
18. PIPE PLUG 1" NPT - Malleable Iron
19. PIPE PLUG 2" NPT - Cast Iron
20. FLOAT BALL - 316 Stainless Steel
21. FLOAT ROD - 316 Stainless Steel

ENGINEERING DATA

Pressure Rating:

Valve body rated 200 psi WOG, tested to 300 psi.
Float tested to 1000 psi.

Working Pressure:

10-75 psi with 5/16" orifice (Optional-Fig. 929-L)
10-150 psi with 3/16" orifice (Standard-Fig. 929)

CONSULT FACTORY IF OPERATING PRESSURE IS LESS THAN 10 PSI.

Maximum Venting Rate:

Fig. 929-L @ 75 psi with 5/16" orifice = 88.8 SCFM
Fig. 929 @ 150 psi with 3/16" orifice = 58.7 SCFM

FOR SIZING AND LOCATING SEE PAGES 16-17. OTHER ORIFICES AVAILABLE; CONSULT FACTORY.

Where to Install Air Valves:

1. Peaks
2. Increased Down Slope
3. Decrease in Upward Slope
4. Long Ascents
5. Long Descents
6. Long Horizontals
7. Pumps
8. Large Valves, Cylinders and Piping Loops