

SIMPLE LEVER

Pressure Type Air Release Valve



FIG. 910

SIMPLE LEVER AIR RELEASE

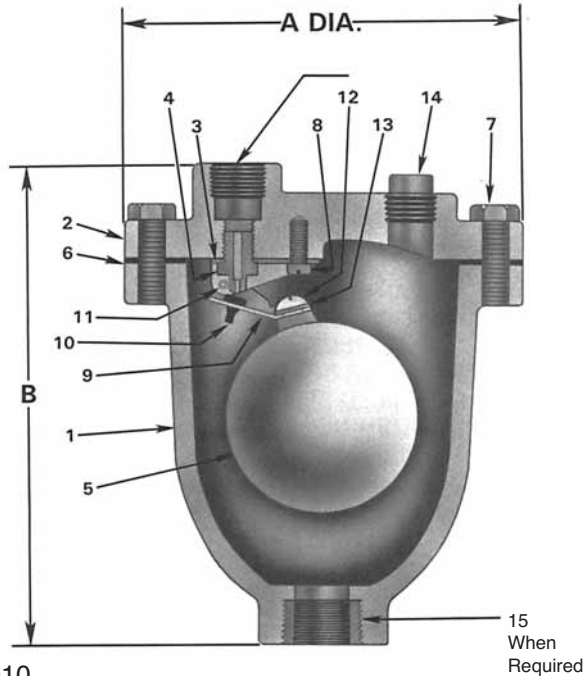

FIG. 910

PARTS LIST

1. BODY - Cast Iron A126 Class B
2. COVER - Cast Iron A126 Class B
3. LEVERAGE BRACKET - 316 Stainless Steel
4. ORIFICE - 316 Stainless Steel
5. FLOAT ARM - 316 Stainless Steel
6. GASKET - Composition
7. COVER BOLTS - Steel Grade 2
8. BRACKET SCREW - 18-8 Stainless Steel
9. FLOAT ARM - 316 Stainless Steel
10. ORIFICE BUTTON - Buna-N
11. COILED SPRING PIN - 302 Stainless Steel
12. FLOAT SCREW - 18-8 Stainless Steel
13. LOCKWASHER - 18-8 Stainless Steel
14. PIPE PLUG - Steel (Commercial)
15. REDUCING BUSHING - Steel (Commercial)

ENGINEERING DATA

Pressure Rating:

Valve body rated 300 psi WOG, tested to 450 psi.
Float tested to 1000 psi.

Working Pressure:

10-150 psi with 3/32" orifice (Standard-Fig. 910)
10-300 psi with 1/16" orifice (Optional-Fig. 910-H)

CONSULT FACTORY IF OPERATING PRESSURE IS LESS THAN 10 PSI.

Maximum Venting Rate:

Fig. 910 @ 150 psi with 3/32" orifice = 14.7 SCFM
Fig. 910-H @ 300 psi with 1/16" orifice = 12.5 SCFM

FOR SIZING AND LOCATING SEE PAGES 16-17. OTHER ORIFICES AVAILABLE; CONSULT FACTORY.

Where to Install Air Valves:

1. Peaks
2. Increased Down Slope
3. Decrease in Upward Slope
4. Long Ascents
5. Long Descents
6. Long Horizontals
7. Pumps
8. Large Valves, Cylinders and Piping Loops

GENERAL DIMENSIONS

VALVE (INLET)	VALVE (OUTLET)	A (DIAMETER)	B (HEIGHT)	WEIGHT (LBS.)
1/2" NPT				
3/4" NPT	3/8" NPT	5-1/8"	6-1/4"	8
1" NPT				

ENGINEERING SPECIFICATION

The Air Release Valve shall be float operated and shall incorporate a simple lever mechanism to enable the valve to automatically release accumulated air from a fluid system while that system is pressurized and operating.

The Air Release Valve shall close drop tight, incorporating an easily renewable Buna-N seat for superior service on water. All internal metal parts shall be of stainless steel. The float shall be of stainless steel and be capable of withstanding a test pressure of 1000 PSIG. The linkage/lever mechanism shall be designed to prevent jamming.

The body and cover shall be of cast iron conforming to ASTM A126 Class B, and shall be designed to withstand a test pressure of 450 PSIG.

The Air Release Valves shall be as manufactured by GA Industries, Inc., their Figure 910 (formerly Figure 1/2-AR, 3/4-AR and 1 AR).